

Chapter 5

Ease of Installation



People

Highway departments can use their own crews to install Snap-Tite®- no special training is necessary. Using minimal equipment, a team of four can easily rehabilitate a culvert. Purchase the Snap-Tite® Culvert Lining Systems today, keep it in your yard until you have some down time and install it that day. What would be lost payroll time becomes a money-saving project.

Product

Snap-Tite® Culvert liner is a tough, flexible liner made from solid-wall HDPE pipe. The ends are machined to make a mechanical connection which provides tensile and compression strength.

Equipment

Snap-Tite® is so easy to install that most jobs can be completed with a backhoe, shovels, two come-a-longs, and chains. If a culvert requires cleaning, a water truck or jet cleaner may be needed.

Chains and come-a-longs are part of the equipment needed to install Snap-Tite® Culvert Liner. Standard chain come-a-longs are available with load ratings of 1,000 to 5,000 lbs. of force. Verify the amount of force that the come-a-longs are capable of applying before using them. For safety reasons, the chains normally are able to handle twice the load applied by each come-a-long.

Chains are sold based on working load. The working load is the normal rating for typical lifting applications. The strength at failure is usually four times the working load. When a chain is wrapped around a Snap-Tite® liner and tightened with a chain binder, it is under tensile loading.

After a come-a-long is attached to a chain link, the link is subject to cross loading. A cross load occurs because the chain must wrap around the pipe to transfer the forces. As the cross load is increased, the angle of the chain around the liner changes. See drawing 1.

Chain manufacturers reduce the working load by 25% for cross loading. A chain with a standard rating of 6,000 lbs. is only rated for 4,500 lbs. in this application. If you have determined that you need 6,000 lbs. working load on the chain for a Snap-Tite® Installation, then an 8,000 lbs. working load rated chain is needed.

Full load is applied when the male and female joints come together straight on and part of the flat surface on both sides “catches.” The best joining procedure is to watch the joining process and make corrections based on observations. When pipe movement requires more force than expected, look for a reason. If the joints do “catch,” rotation of the two liner sections or alignment with a pry bar may solve the problem.

Drawing 1: Chain Wrap Position

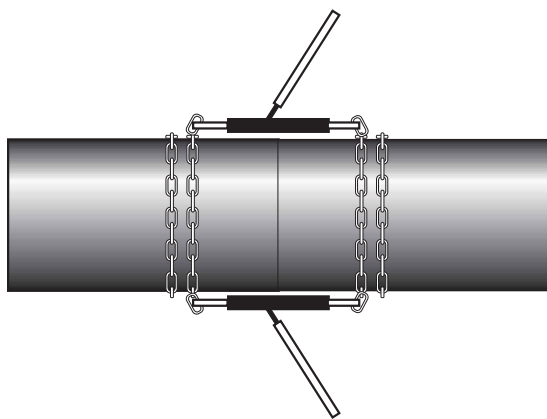

Position of chain before load – Top View

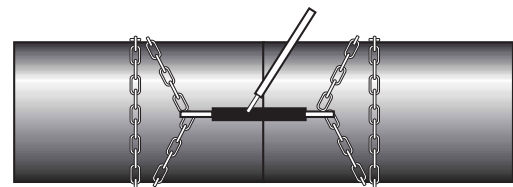

Chain under load – Side View

If the male end is at a slight angle to the female and partially inserted, lower force is required to make the joints mate. Apply force from one come-a-long until liner bends slightly. Apply force slowly, this allows the female joint to expand. Be cautious when tightening a chain or cable!

Joining forces changes with temperature, type of lubrication, male-female joint alignment,

presence of debris, slope and time. Forces are estimated for slow application of force with flat slope and lubricated joint. A slow application of force allows materials to stretch. Fast joining requires more force and energy because material does not immediately increase in size. More force will be required below 73 degrees Fahrenheit. Forces are estimated only!

**Table 5-1
Estimated Force to Join Snap-Tite® Liner**

Liner Size OD (Inches)	Weight per foot (lbs.)	Weight of 24 feet (lbs.)	Estimated Joining Force (lbs.)	Total Force (lbs.)	Min. Load Rating for Each Come-along
10.75	4.75	114	500	614	1,000 lb.
12.75	6.67	160	1,000	1,160	1,000 lb.
14	8.05	193	1,000	1,193	1,000 lb.
16	10.50	252	1,000	1,252	1,000 lb.
18	13.30	319	1,000	1,319	1,000 lb.
20	20.34	488	1,000	1,419	1,000 lb.
22	19.86	477	1,000	1,477	1,000 lb.
24	23.62	566	1,500	2,066	2,000 lb.
28	32.19	773	1,500	2,273	2,000 lb.
30	36.93	886	1,500	2,386	2,000 lb.
32	42.04	1,009	2,000	3,009	3,000 lb.
36	53.20	1,255	2,000	3,255	3,000 lb.
39.37	63.69	1,529	3,000	4,529	3,000 lb.
42	72.37	1,737	3,000	4,737	3,000 lb.
48	94.96	2,279	3,000	5,279	3,000 lb.
54	119.7	2,873	3,000	5,873	3,000 lb.
63	162.98	3,912	4,000	7,912	4,000 lb.

Installation Steps

Step 1 – Select and prepare the existing culvert. Inspect the culvert to ensure the liner can be inserted without obstruction. Flush and/or clean the existing culvert.

Culvert must first be cleared of any objects that may obstruct the insertion of the liner.

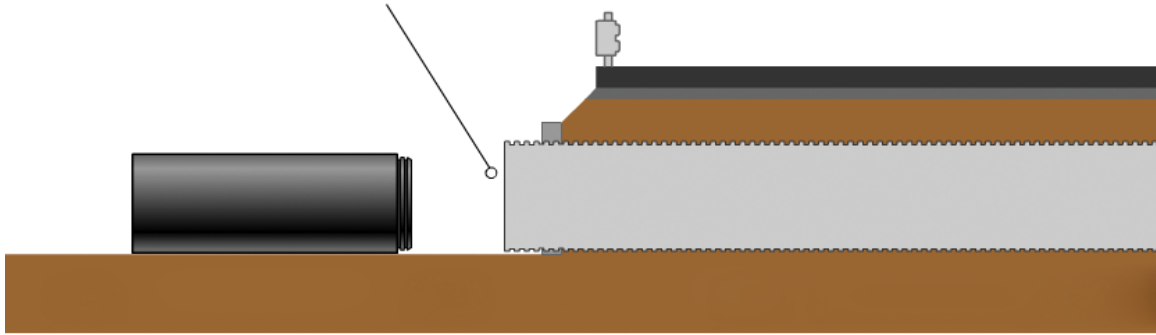

Pieces of wood are used to maintain grade and alignment

Step 2 – Insert one end of Snap-Tite® Culvert Liner into existing culvert. This can be done using a variety of techniques. Leave about five feet of liner exposed. Prior to installation of first section, it may be necessary to create a “nose cone” by cutting the ends of the pipe.

One end of the liner is inserted into the culvert.

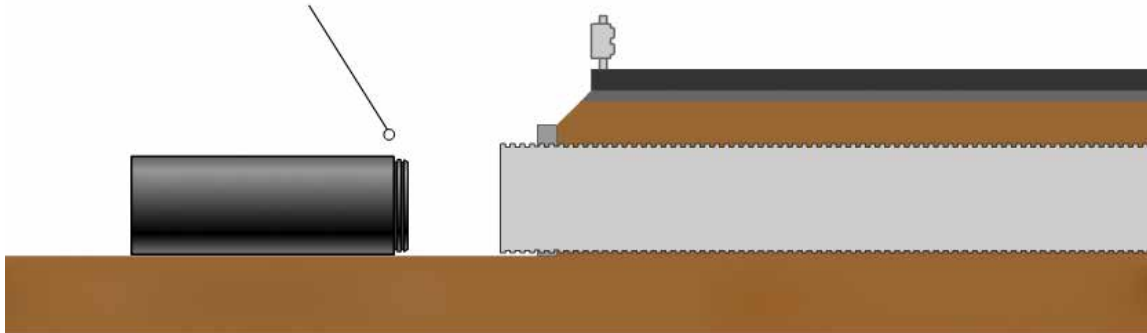

Typical Nose Cone Construction

Make 8 Dove Tails. Drill hole $\frac{1}{2}$ about 1" from point of Dove Tail.

Draw pieces toward each other by connecting wire to opposite holes and twisting the wire to tighten.

All dimensions can be varied to suit specific conditions.



Step 3 – Position the next section of Snap-Tite® Culvert Liner with proper alignment.
Place the opposing end of a second section against the exposed end of the first section.
The two sections must be in alignment and have the same slope.

The next section is aligned with the first.

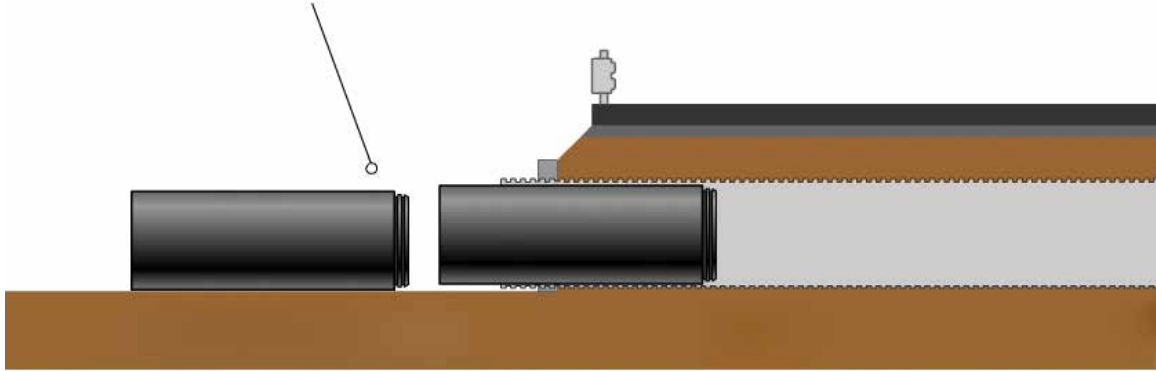

Step 4 – Lubricate the male side of Snap-Tite® joint. A gasket is normally supplied with Snap-Tite® pipe. It is installed on the male end to help make a watertight seal, and should be placed in the first groove. Make sure that one end of the gasket is touching the side of the groove that is closest to the end. Check the alignment of the gasket around the liner. Apply lubricant to the entire circumference of the liner. The lubricant must be applied evenly to reduce the chance of a torn or rolled gasket.

Lubricants

Most standard pipe and gasket lubricants can be used with Snap-Tite® Culvert Liner and gaskets. Aromatic hydrocarbons (like gasoline) and most petroleum-based lubricants must be avoided. Vegetable oil and mineral oil are acceptable in most formulations.

In environmentally challenging applications, spray-on lubricants like SLIKSTYX™ may be the best choice. SLIKSTYX™ can be applied at low concentrations.

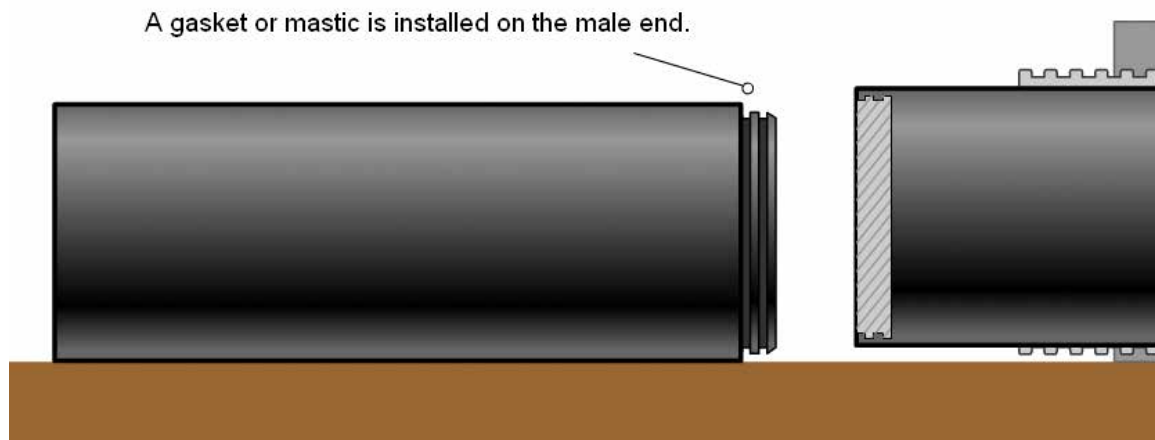

Option: Mastic can be applied to second large groove to reduce chance of leakage when joints are deflected. Carefully apply mastic to large groove. Too much or too little mastic can increase chance of leakage. (See Drawing 2: Male End of Snap-Tite® and Completed Snap-Tite Joint)

Step 5 – Attach the chains and couplings. Double-wrap the chains approximately four feet from the coupling end and tighten with binders. Attach one come-a-long on each side of the couplings, 180 degrees apart.

Chains and binders are attached and tightened until liner snaps together.

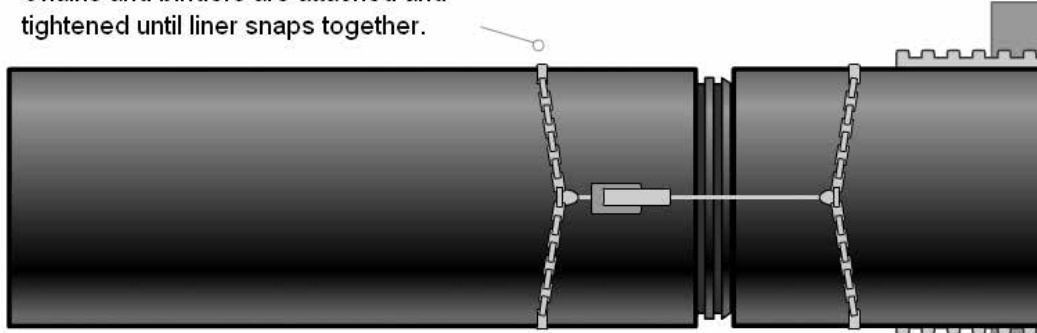

Step 6 – Snap liner together. Align the ends of the male bevel inside the female bevel. Use a pry bar or move the come-a-longs to different positions on liner if pipe is out of round to improve alignment. Be sure male end has been properly lubricated. Pull the couplings together slowly, forcing the female end to expand and allow the male end to move into the female end. Apply force slowly and make observations. Apply force to one side until liner slightly deflects, then apply force on other side. Look for the female side to increase in OD as force is applied.

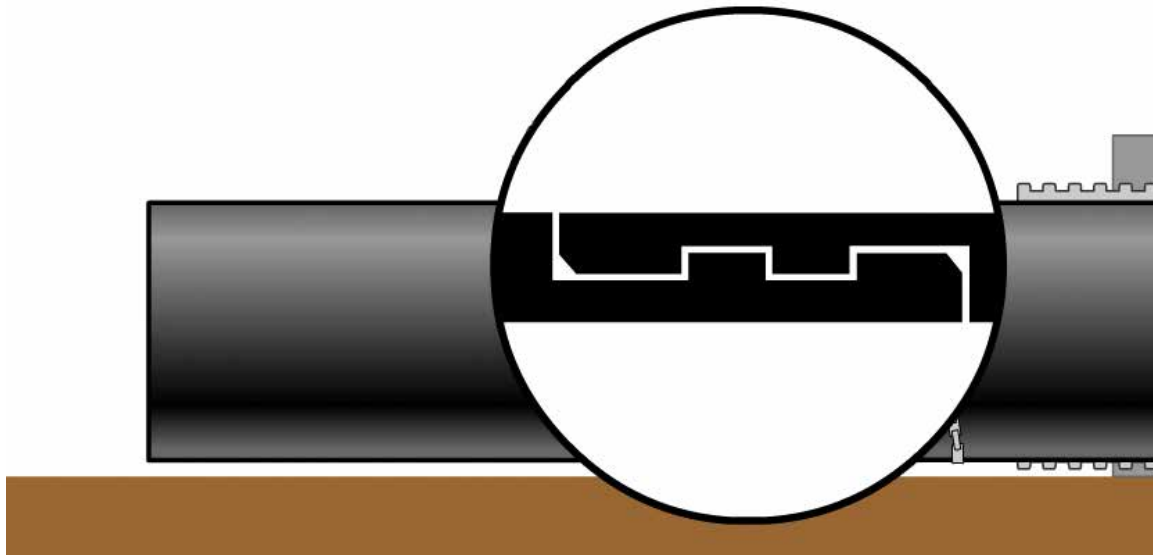
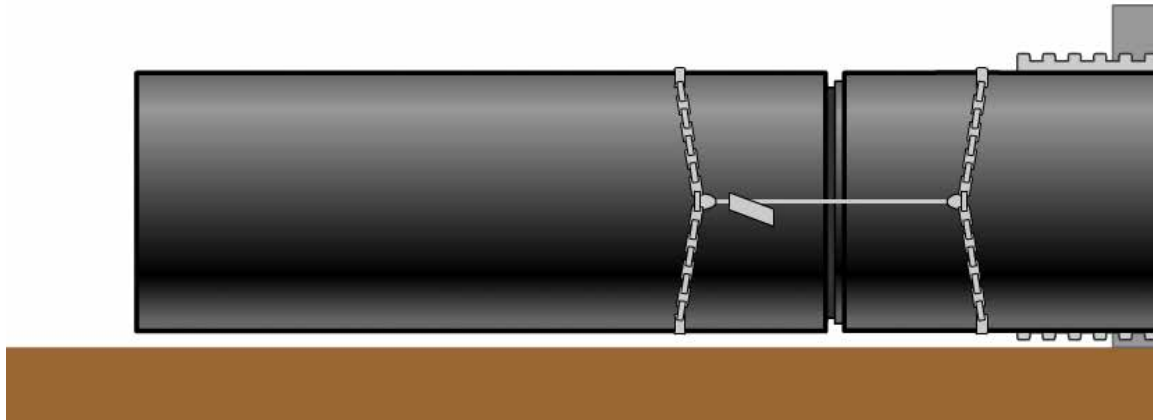

Caution! If chain or come-a-long appears to be overstressed, stop operation! Quickly move away from the chain! When ends and grooves are aligned, the couplings will “snap” and lock together. Allow time for this to occur. If operation is stopped, check alignment. Often poor alignment or a stone or dirt in the end causes the need for additional pressure. Rotation of the liner will change alignment. Clean out the joint if needed.

Step 7 – Push joined liners into culvert and repeat until completely lined. Remove chains, push joined liners into culvert and repeat steps 1-6. Each new piece of pipe is snapped onto the preceding pipe and pushed into the culvert, leaving enough pipe protruding from the culvert to join with the next length of liner.

Joined liners are then pushed into the culvert. Process is repeated until the culvert is completely lined.

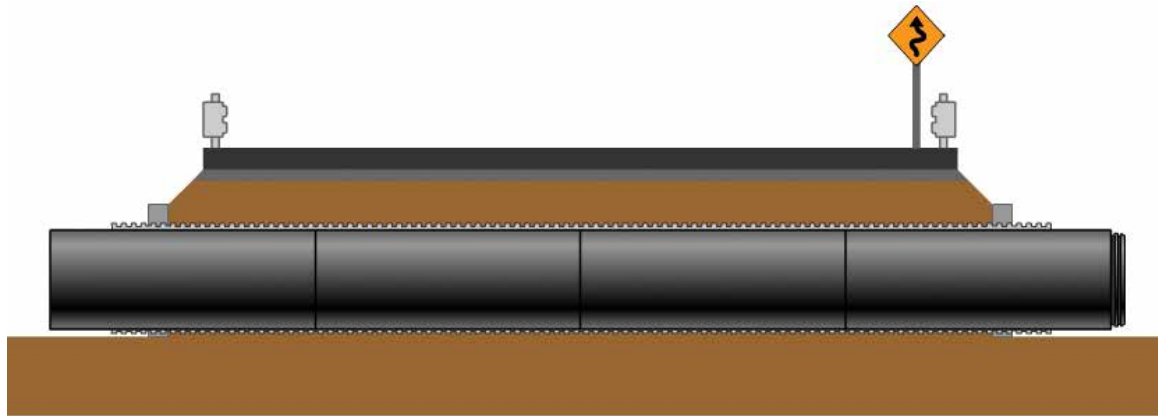
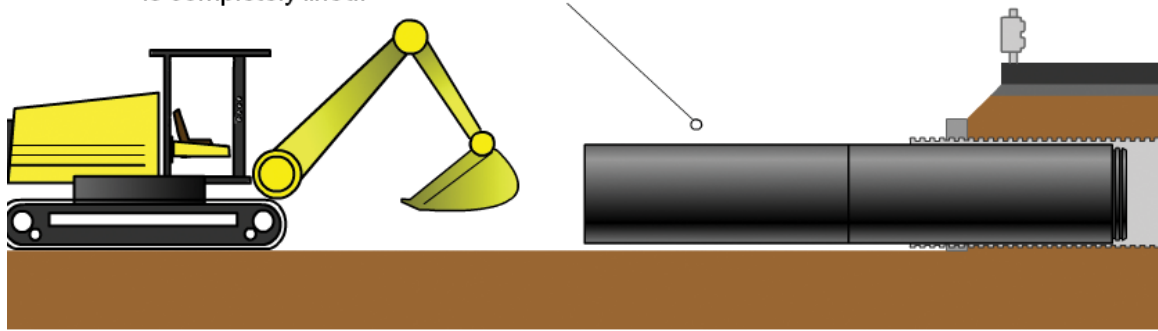

Step 8 – Seal the culvert ends. Make an end seal for the annular space a distance of one to two feet at each end using an appropriate grout. A relatively dry cement grout is used in most situations. Chemical grout, oakum, and other seals are used depending upon the situation. See Chapter 6, Annular Space Grouting.

Ends are sealed. Pipes are inserted to drain any water, to vent air and allow for grout injection. The annular space is then grouted. Grouting is similar to backfilling, as it provides support for the road and liner.

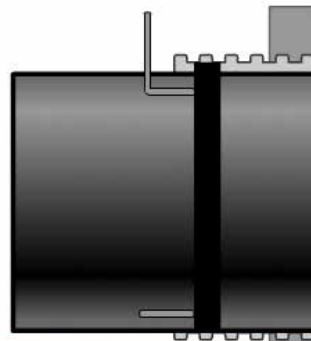
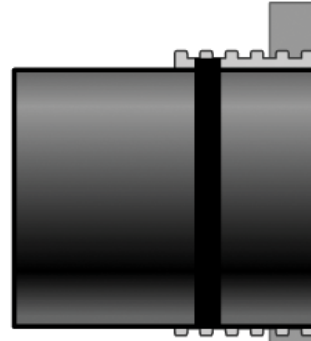

Step 9 – Grout the annular space. It is recommended that the annular space between the existing culvert and the liner be grouted. This will help fill the voids created by previous washouts, provide additional structural support, and prevent point loading.

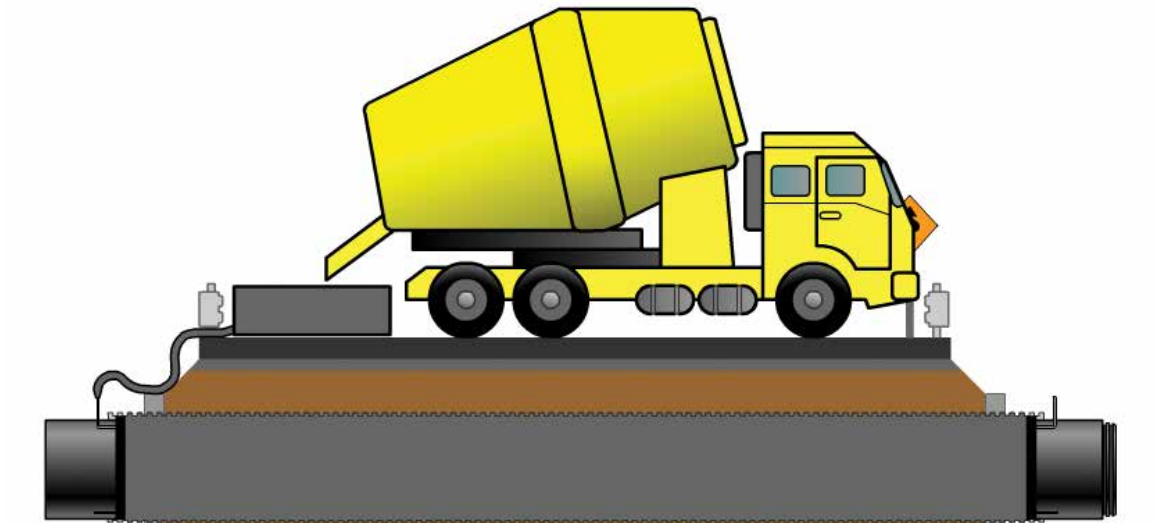
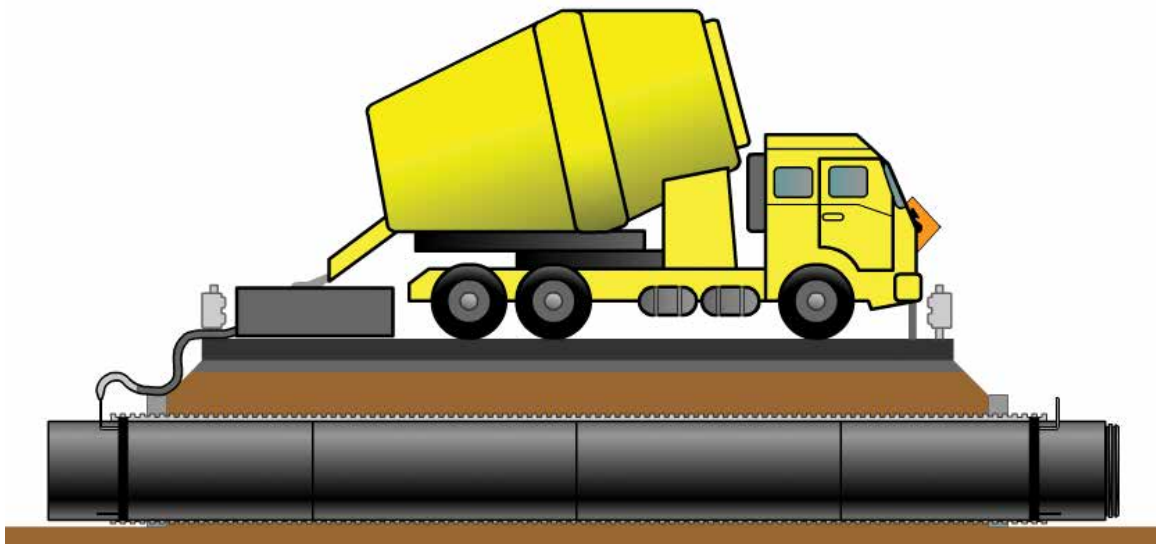

See Chapter 7, Annular Space Grouting.
Additional information is available by calling your Snap-Tite® representative.

Step 10 – Angling the Inlet Structure. After grouting the annular space, complete work on inlet and outlet structure. Angling the inlet structure can improve flow into lined culvert.

See Chapter 6, End Seals, Wing Walls and Bulkheads or Hydro-Bell in Chapter 3, Hydraulics.

